



Operating Instructions

Varioshake Shaking Incubator
VS 60 OI



The Shaking Incubator LAUDA Varioshake VS 60 OI is universally applicable for all tasks in standard and research laboratories that require exactly reproducible orbital motions and temperatures and a clear view of the cultures, for example in incubations, fermentations, homogenisations, chemical and biochemical reactions, enzyme and tissue studies.

Temperature and shaking frequency are microprocessor-controlled. The temperature can be set within a range of 20 °C (from approx 8 K above ambient) to 70 °C. The shaking frequency can be set from 20 min⁻¹ to max 250 min⁻¹ and operates with a fixed amplitude of 30 mm. The micro-processor-controlled timer continuously displays the current remaining incubation time and emits an acoustic signal at end of time.

Control panel with main switch as well as display and operating elements of the timer and the electronic regulators for interior temperature and shaking frequency.



Before installation, please check whether contents of package are in good order and complete. Should you note any damages or have any reasons for complaint, please contact your supplier or directly:

LAUDA-GFL Gesellschaft für Labortechnik mbH
Schulze-Delitzsch-Str. 4+5
30938 Burgwedel - Germany
Telefon: +49 (0)5139 9958 0
Fax: +49 (0)5139 9958 21
E-Mail: info@lauda-gfl.de
Internet: www.gfl.de

Content

Operating Instructions	1
1 Use of the Shaking Incubator.....	7
1.1 Intended Use.....	7
1.2 Improper Use	7
2 Warranty	7
3 Before installation	7
4 Transport, Assembly and Location of the Shaking Incubator	8
5 Operating Voltage.....	8
6 Inbetriebnahme	8
6.1 Operation	9
6.2 Cooling Coil.....	9
6.3 Operation and display elements of the control panel.....	9
6.3.1 Incubation time	10
6.3.2 Incubation temperature.....	11
6.3.3 Shaking frequency.....	11
6.4 RC Operation via PC.....	12
6.5 Shutdown.....	12
7 Error Codes and Temperature Cut-out	12
7.1 Error Codes.....	12
7.2 Temperature Cut-out	13
8 Functional description	13
9 Maintenance, Support and Repair.....	13
9.1 Cleaning and Disinfection.....	13
9.2 Temperature Adjustment.....	14
9.3 Checking the Acrylic Glass Cover	14
9.4 Shutdown caused by overload or power failure	14
9.5 Exchanging the fuses.....	14
9.6 Maintenance Procedures	14
10 Disposal of Old Units.....	15
11 Technical Data	16
11.1 Varioshake Shaking Incubator VS 60 OI	16
12 Circuit Diagram	17
12.1 Varioshake Shaking Incubator VS 60 OI	18
13 Connection to the mains supply	19
13.1 Electrical fuses	19
14 List of spare parts	20
14.1 Varioshake Shaking Incubator VS 60 OI	20
15 Accessories.....	22

1 Use of the Shaking Incubator

1.1 Intended Use

Die Informationen dieser Bedienungsanleitung müssen unbedingt gelesen und beachtet werden. Nur dann ist die einwandfreie Arbeitsweise des Schüttelapparates gewährleistet. Nur Personen, die sich mit dieser Bedienungsanleitung vertraut gemacht haben, dürfen die Geräte installieren und bedienen. Die Frequenz der Schüttelbewegung ist elektronisch geregelt einstellbar. Zu schüttelnde Laborgefäße sind durch den Einsatz entsprechender Zusatzeinrichtungen betriebssicher zu fixieren. Die maximal nutzbare Bewegungsfrequenz wird durch Art und Gewicht der Nutzlast mitbestimmt. Zum sicheren Abstellen eingesetzter Zusatzeinrichtungen ist ausreichend Arbeitsfläche im direkten Umfeld des Gerätes einzuplanen.



Caution:
due to high risk of injuries, never reach into the unit while the shaking device is still in operation.

1.2 Improper Use

LAUDA Varioshake Shaking Incubators must not be used in potentially explosive environments. The temperature work and the shaking motion must not create an explosive atmosphere in the vicinity of the unit.

LAUDA Varioshake Shaking Incubators, operated in a laboratory, are no Medical Devices. They fall neither under national nor international Medical Device Directives and have to be used and applied accordingly.

2 Warranty

For all laboratory apparatus and their accessories from LAUDA-GFL Gesellschaft für Labortechnik mbH, there is a warranty claim, as well for spare parts, repairs and modifications, carried out by LAUDA-GFL. In order to identify defective units, we require both model and serial number on the nameplate of the Shaking Incubator and, if applicable, a copy of the invoice.

3 Before installation

The information in these operating instructions must by all means be carefully read and observed. Only then a perfect functioning of the Shaking Incubator can be guaranteed.

Vital information within the manual are emphasized in bold letters. Safety precautions are additionally marked with the following symbols.



Read and observe the operating instructions



Warning of hand injuries



Warning of hot surfaces



Warning of dangerous electrical voltage



General warning

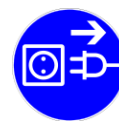

Before maintenance and repair disconnect the unit all-pole from the electrical mains (pull the plug from the socket).

4 Transport, Assembly and Location of the Shaking Incubator

Provide suitable transport means to transport the unit to the location. Doors, lifts and hallways/ corridors to the location must permit safe transport.



Caution:
the Shaking Incubator weighs 51 kg. Lift and carry the unit with at least two persons when transporting it to the location.

Place only on firm, stable and level surfaces indoors. The location must offer sufficient space and must safely carry the total weight of the unit (unit weight as per technical data, chapter 10 of these operating instructions, plus weight of the load).

For safe handling of removed, warmed-up loads make sure to allow sufficient workspace in the direct vicinity of the unit. The unit is not approved for operation in potentially explosive surroundings.

5 Operating Voltage

The Shaking Incubator must only be connected to a properly installed power connection with earth conductor (PE), according to the local regulations. The Shaking Incubator is an electric appliance, protection class I, therefore, a connection to earth conductor (PE) must be provided. The value of the required mains fuse is stated in the technical data, chapter 11 of these instructions. The electrical connection must be configured so as to secure that power can be cut all-pole at any time.

It must be secured that, even after opening the cover, the mains connection cable does not touch any warm parts of the interior or of removed, warmed-up load. The main switch on the control panel of the Incubator must be off (position O). The operating voltage stated on the nameplate (on the back of the unit) must be identical to the mains voltage. If they are identical, connect to the mains.



6 Inbetriebnahme



Caution:
due to high risk of injuries, never reach into the unit while the shaking device is still in operation.



Caution:
make sure that neither the shaking movement nor the heating process create an explosive atmosphere near the Shaking Incubator during operation.



Caution:
hot surfaces in the interior when temperature is set to 50 °C or more. Danger of burns. Wearing suitable safety gloves is recommended.

6.1 Operation



After switching on the main switch the fan motor starts.

Incubation time, incubation temperature and shaking frequency must be set and activated individually. The shaking motion and the heating can only be initiated when the cover is closed and will be cut off when the cover is opened. Please refer to the following pages for instructions on initiation of the individual functions.

6.2 Cooling Coil

The serial cooling coil for connection to the domestic water supply increases the temperature range of the Shaking Incubator (lowest operating temperature of the Incubator +20 °C). The connections of the cooling coil are situated at the back of the unit. Cooling water is to be supplied to the Shaking Incubator through pressure-proof water hoses with an interior diameter of approx. 13 mm. The connected hoses are to be secured with hose clamps (hoses and clamps are not part of the standard scope of supply).

6.3 Operation and display elements of the control panel

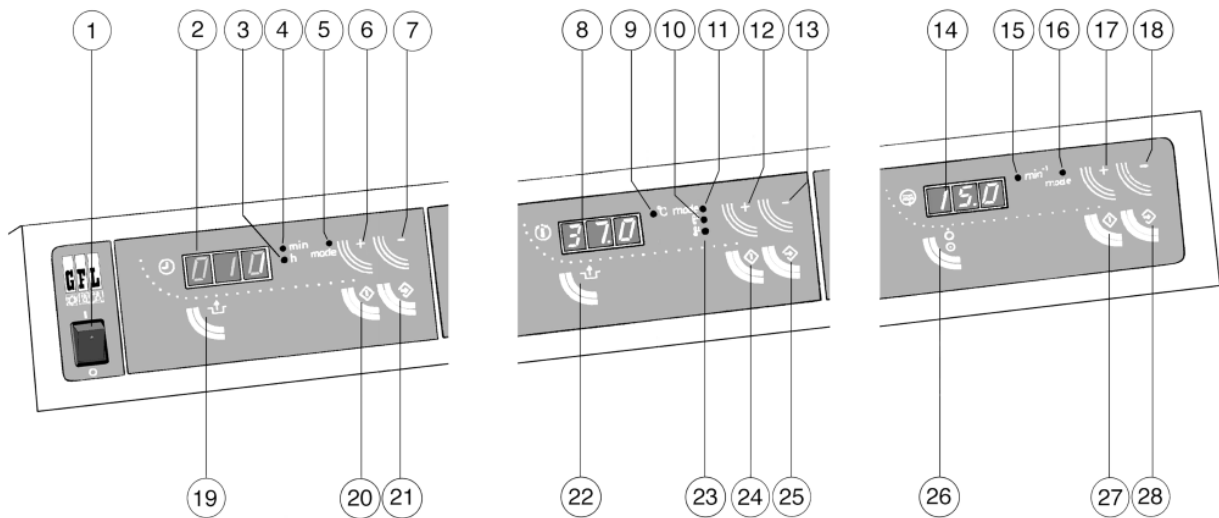

1 Main switch

Operation panel incubation time

- 2 Display incubation time
- 3 Pilot lamp "time" in the display, hours
- 4 Pilot lamp "time" in the display, minutes
- 5 Pilot lamp "total run-time" in the display
- 6 Change-over key for total run-time and for entry of higher set points
- 7 Entry of lower set points
- 19 Key to switch off alarm signal after expiry of preset run-times
- 20 Change-over key for alteration of set points
- 21 Confirmation of new total run-times

Operation panel temperature controller

- 8 Display for set and actual temperatures
- 9 Pilot lamp "actual temperature" in the display
- 10 Pilot lamp difference value of over-temperature alarm in the display
- 11 Pilot lamp set temperature in the display
- 12 Change-over key between display and entry of higher set points
- 13 Entry of lower set points
- 22 Key to switch off alarm signal
- 23 Pilot lamp difference value of under-temperature alarm in the display
- 24 Change-over key for alteration of set points
- 25 Confirmation of new set points 9 Kontrolllampe Ist-Temperatur im Display

Operation panel shaking frequency control

- 14 Display for actual and set shaking frequencies
- 15 Pilot lamp "actual shaking frequency" in the display
- 16 Pilot lamp "set shaking frequency" in the display
- 17 Change-over key between the displays and entry of higher set points
- 18 Entry of lower set points
- 26 Shaking movement on/off
- 27 Change-over key for alteration of set points
- 28 Confirmation of new set points

6.3.1 Incubation time

Press key 20 of the keypad to switch the timer to entry mode.

The display begins to flash and pilot lamp 4 glows (display in minutes). The required incubation time can now be set by pressing keys 6 (+) and 7 (-) (max. 59 minutes). Press key 21 to confirm the set minutes. The entry mode then switches to entry of set hours. Pilot lamp 3 glows. Use keys 6 (+) and 7 (-) to set the required incubation time in hours (max. 999 hours). Press key 21 to confirm the set hours. The timer is now activated, the set incubation time starts to run down. After activation of the timer the set incubation time can only be interrupted or altered by switching the Shaking Incubator off with the main switch.

The currently remaining run-time is shown in the display. If the remaining run-time is more than one hour, pilot lamp 3 glows. The time is displayed in hours. If the remaining run-time is less than one hour, pilot lamp 4 glows. The time is displayed in minutes. While the incubation time is running down, press key 6 to choose between display of the remaining run-time and the set total run-time. When display of the total run-time is chosen, pilot lamp 5 glows. Approx. 30 seconds after the last entry, the digital timer switches back to normal operation mode. Expiry of the set incubation time is signalled by a continuous acoustic alarm. Press key 19 to switch off the alarm signal. The timer merely triggers the alarm signal; the unit is not switched off automatically.

6.3.2 Incubation temperature

The microprocessor-controlled PID-type regulation permits quick availability of the set temperature, at the same providing a high temporal temperature constancy of ± 0.2 K. Display as well as setting the temperature is done digitally on an LED display, in 0.1 K increments. The operating temperature is approx. 8 K above ambient temperature to 70 °C. The serial cooling coil for connection to the domestic water supply or to a refrigerated circulator permits operation at set temperatures as of 20 °C.

After switching the unit on, display 8 flashes and shows the last memorized set temperature, pilot lamp 11 glows. Use keys 12 (+) and 13 (-) to enter a new set temperature. Press key 25 to confirm the set temperature. The temperature controller starts operation. Approx. 30 seconds after the last entry pilot lamp 11 goes out and pilot lamp 9 glows. The display now switches from set temperature to actual temperature.

Three different temperatures can be selected and changed by pressing key 12:

1. Set temperature, pilot lamp 11 glows.
2. Difference point for over-temperature alarm, dependent on the set temperature (set temperature plus difference point = alarm point), pilot lamp 10 glows. Factory aligned at 04.0 = 4.0 K.
3. Difference point for under-temperature alarm, dependent on the set temperature (set temperature minus difference point = alarm point), pilot lamp 23 glows. Factory aligned at 09.0 = 9.0 K.

When key 24 is pressed, the displayed set point starts to flash and can be reset through keys 12 (+) and 13 (-). Press key 25 to confirm the new set point. Over-temperature and under-temperature alarms are signalled acoustically as well as visually by error codes in the display. For further information on this subject, please see chapter 7.1 Error Codes of these instructions. When opening the Incubator's cover, both heating and shaking drive will be switched off. After closing the cover, the Incubator will restart with the set values of temperature and shaking frequency.



Caution,
the temperature in the Incubator's interior may rise up to 70 °C during operation. Danger of burns. Wearing suitable safety gloves is recommended.

6.3.3 Shaking frequency

An overload-protected a. c. motor produces an orbital shaking motion with a shaking amplitude of 30 mm through the robust, durable drive mechanism. The motor is controlled through a PID type microprocessor frequency regulation. The shaking frequency can be set between 20 min^{-1} to 250 min^{-1} , independent of the load. It is equipped with a gentle start-up and can be set in increments of 1 min^{-1} .

Press key 26 to switch the shaking movement on and off. After switching on the shaking device, the Incubator starts shaking with the last set shaking frequency. Pilot lamp 15 glows, display 14 shows the actual shaking frequency. In order to reset the shaking frequency, first press key 17 and then 27. Pilot lamp 16 glows, the display flashes and shows the set shaking frequency. Use keys 17 (+) and 18 (-) to reset the displayed value. Press key 28 to confirm the new set value. Even when the shaking device is switched off, the set shaking frequency can be read by pressing key 17 (pilot lamp 16 glows = set frequency). It can be reset as described above. Approx. 30 seconds after the last entry the Incubator automatically switches back to operation mode (shaking device on or off). To switch off the shaking device, press key 26. The shaking frequency is cut off slowly, the operation panel is switched off.

When opening the Shaking Incubator's cover, a control switch will cut off both heating and shaking device. After closing the cover, the Incubator will restart operation with the set values of temperature and shaking frequency.



Caution:

only after the shaking platform has come to a complete stop, the cover may be opened to reach into the unit.

6.4 RC Operation via PC

An interface module with a terminal on the back of the Incubator produces the data transmission format RS 232. The interface enables reading of current actual and set values at any time. In order to set values for the temperature and shaking frequency in a defined time-span, the Incubator has to be switched to remote control mode via a PC signal. Being in remote control mode, the incubator cannot be operated manually. An interface protocol is available for operation of the Shaking Incubator's RS 232 interface. Please advise model and serial number of the incubator.



Caution:

before operating the unit in RC mode, both unit and interior assembly of the Incubator must be carefully checked. The Incubator must be operated in direct sight. Take special care in the vicinity of the automatically operated unit.

6.5 Shutdown

To turn off the unit for longer shutdown times, first switch the main switch to position O and disconnect the unit from the mains. Empty the interior, if necessary, dry and clean the interior to prevent bacterial contamination.

7 Error Codes and Temperature Cut-out

7.1 Error Codes

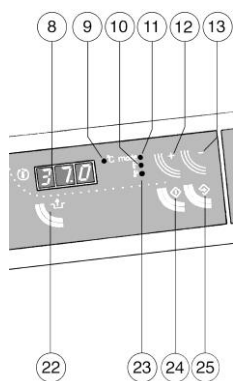

The alarm functions for over- and under-temperature are switched on once the set temperature has been reached for the first time after the temperature regulation has been started. Errors that are due to external influences or to an operational fault are shown acoustically and visually. The display shows either E01 for over-temperature alarm, or E02 for under-temperature alarm. The heating is switched off until key 22 is pressed to cut off the alarm signal.

In case of under-temperature the acoustic alarm is cut off immediately, the visual alarm is cut off after exceeding the set alarm point. In case of over-temperature both acoustic and visual alarms are switched off at the same time. If the alarm occurs recurrently, the Incubator should be checked by a trained electrician.

7.2 Temperature Cut-out

As an additional safety precaution to over-temperature and under-temperature alarms, a thermostatic temperature cut-out protects the unit against overheating. If either temperature regulator or fan motor should fail, the thermostatic over-temperature cut-out will prevent overheating of the incubator. Only after the unit has cooled down, the temperature cut-out, which is situated at the back of the Incubator, can be deblocked. For deblocking, loosen the black cap nut on the back of the unit. Within the thread, a white plastic pin will now be visible which must be gently pushed inside (e.g. with a pen) until a soft clicking sound can be heard. After deblocking, watch the operation of the Shaking Incubator carefully. If the fault re-occurs, the cause has to be removed by a trained electrician.

8 Functional description

A cover made of 8 mm thick acrylic glass encompasses the cabinet interior. The interior is heated by a heating element in a temperature range of 20 °C (from approx. 8 K above ambient) to 70 °C. The fan optimises the temperature distribution. The built-in cooling coil permits works at set temperatures near to the ambient temperature. The temperature controller is a PID controller and is equipped with a monitoring function that signals malfunctions and switches off the heating in case of a malfunction.

The shaking device in the cabinet interior is driven by an a.c. motor, is electronically controlled and permits orbital motions from 20 to 250 min⁻¹ and a fixed shaking amplitude of 30 mm.

The timer allows times to be set between 1 minute and 999 hours and 59 minutes. The timer continuously shows the current remaining run time and emits an acoustic expiration signal.

The electronic regulation is microprocessor-controlled.

The housing is made of lacquered, moulded ABS resin elements and of electrolytically galvanised and powder-coated sheet steel. The shaking platform, made of anodised aluminium, is equipped with four plastic pins for secure attachment of accessory equipment. The heating element and the cooling coil as well as the rear wall and bottom plate of the interior are made of stainless steel.

An RS 232 interface, set into the rear side of the unit, not only serves to register set and actual values of temperature and shaking frequency, but also for remote operation through PC.

9 Maintenance, Support and Repair

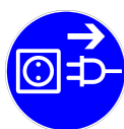

Caution:

Before opening the Distillation Apparatus as well as before cleaning procedures, disconnect the unit from the mains! (Unplug the unit or switch off the main switch).

Danger of electrical shock!

9.1 Cleaning and Disinfection

The lacquered or powder-coated surfaces of the housing, the shaking platform made of anodised aluminium and the acrylic glass cover may be cleaned with mild, non-abrasive and pH neutral detergents. Never use solvent-containing cleaning agents. The stainless steel surfaces of the interior can be cleaned and the original shine be restored with commercial stainless steel polishing agents (e. g. "Helios Brillant" from M/s Ecolab).

To disinfect the Shaking Incubator by a wipe process, approved disinfecting agents with proven compatibility with stainless steel, lacquered or powder-coated steel and ABS resin elements, aluminium or acrylic glass can be used. The instructions for use of the disinfectant must by all means be observed. If in doubt, test the disinfectant in a small local area. Should the Incubator have been contaminated with dangerous substances, cleaning and decontamination measures must be carried

out according to the safety data sheets of these substances. It may be necessary afterwards to have the unit tested for function and safety by a trained electrician or by the service department in the manufacturing plant.

9.2 Temperature Adjustment

LAUDA Varioshake Shaking Incubators are set and adjusted at a temperature of 45 °C. Instructions for adjustment of the temperature regulator are available on request for adjustment purposes during maintenance. Please state model and serial numbers of the Shaking Incubator.

9.3 Checking the Acrylic Glass Cover



The acrylic glass cover is connected to the unit's housing by hinges. The closing motion of the cover is slowed down by two gas pressure springs for safety reasons. The safe function of these gas pressure springs must be checked in regular intervals when opening and closing the cover. Make sure that the cover does not fall down undamped.

9.4 Shutdown caused by overload or power failure

The drive motor of the shaking device is protected against over-heating due to overload. The device will be switched off. Caution, after the motor has cooled down, the shaking device restarts automatically (without gentle start-up control). After a mains failure, the Incubator does not restart automatically, but has to be started as described in chapter 6.

9.5 Exchanging the fuses



The unit's two fuses are situated in a drawer below the unit's plug. In order to check or to exchange these fuses, press the fixing clips on both sides of the drawer and pull.

The fuses may only be exchanged against 4 Amp fuses of the same type. Information on the fuse type can be found on the nameplate next to the unit plug and in the spare parts list of these operating instructions. If the unit is shut down due to an operation fault, always switch it off on the main switch before opening the cover and touching parts in the unit's interior.

9.6 Maintenance Procedures

Please do not hesitate to contact your local dealer or us for technical support. Please contact your dealer or us before returning a defective unit and do not return it before consulting us. A defective unit may only be returned thoroughly cleaned, decontaminated, if necessary, and carefully packed, accompanied by a detailed description of the defect, to

LAUDA-GFL Gesellschaft für Labortechnik mbH
Schulze-Delitzsch-Straße 4+5
D-30938 Burgwedel

Servicings, repairs and modifications must be carried out according to the General Technical Rules and Regulations (§2, chapter 2, BGV A3) by a trained electrician (§2, chapter 3, BGV A3). Only original spare parts may be used. Always demand a confirmation (company, date, signature) on the kind and extent of the service(s) carried out.

10 Disposal of Old Units

LAUDA-GFL will take responsibility, within the scope of the legal directives, for an environmentally sound handling and disposal of all used LAUDA-GFL units as of the production year 1995 that are returned to us free of charge and will have it materially recycled. Before the unit is returned, a legally binding declaration must be provided from the sender, confirming that the unit is free from harmful and/or hazardous contaminations as well as from hazardous substances caused by the previous use of the unit. LAUDA-GFL laboratory apparatus are exclusively designed for industrial use and may not be disposed of through public waste disposal authorities.

EAR Registration Number WEEE-ID.NO.DE 67770231

11 Technical Data

11.1 Varioshake Shaking Incubator VS 60 OI

Exterior dimensions (W x D x H)	560 mm x 690 mm x 630 mm
Interior dimensions (W x D x H)	450 mm x 450 mm x 360 mm
Volume / Capacity	Approx. 60 l accepts one shaking tray A000045
Maximum load depending on weight of load and set shaking frequency	up to 12 kg
Control	digital
Temperature range (Incubation)	+20 °C (from approx 8 K above ambient) to +70 °C serial built-in cooling coil
Temperature constancy (temporal)	+/- 0,2 K
Over-temperature cut-out	electronically settable up to 9.9 K above the set value, to protect the test substances
Under-temperature cut-out	electronically settable up to 9.9 K below the set value, to protect the test substances
Temperature limiter	electromechanical temperature limiter with capillary tube sensor, cut-off temperature 135 °C / -10 K
Shaking motion type	orbital, can be switched on and off
Shaking amplitude	30 mm
Shaking frequency	20 - 250 min ⁻¹ depending on load
Incubation time	1 min – 999:59 h
Electrical connection / Mains connection	230 V, +/- 10 %, 50 / 60 Hz
Mains fuse	
On-site	10 A
Internal	4 A T
Power	650 W
Protection class / - type	I / IP20
Environmental conditions	only for indoors use (not in potentially explosive surroundings)
Ambient temperature	+ 10 °C to + 30 °C
Humidity	max 70 % relative humidity, non-condensing
Emission sound pressure level	< 70 dB (A)
Weight	51 kg

12 Circuit Diagram

A1	Electronic control power board
A2	Electronic control timer
A3	Electronic control temperature regulator
A4	Electronic control shaking frequency
A5	Pulse generator
A6	Interface inlet RS 232
A7	Line filter
B1	Temperature sensor PT100
C1	Motor condenser
E1	Tubular heating element
F1	Fuse 4 A T
F2	Fuse 4 A T
F3	Temperature limiter
M1	Fan motor
M2	Drive motor
S1	Main switch
S2	Control switch lid
S3	Change-over key for display of total run-time or entry of higher set points
S4	Entry of lower set points
S5	Switch off alarm signal
S6	Change-over key alteration of total run-time
S7	Confirmation of new total run-times
S8	Change-over key display and entry of higher set points
S9	Entry of lower set points
S10	Switch off alarm signal
S11	Change-over key alteration of set points
S12	Confirmation of new set points
S13	Change-over key display and entry of higher set points
S14	Entry of lower set points
S15	Shaking movement on / off
S16	Change-over key set points
S17	Confirmation of new set points
V1	Triac

12.1 Varioshake Shaking Incubator VS 60 OI

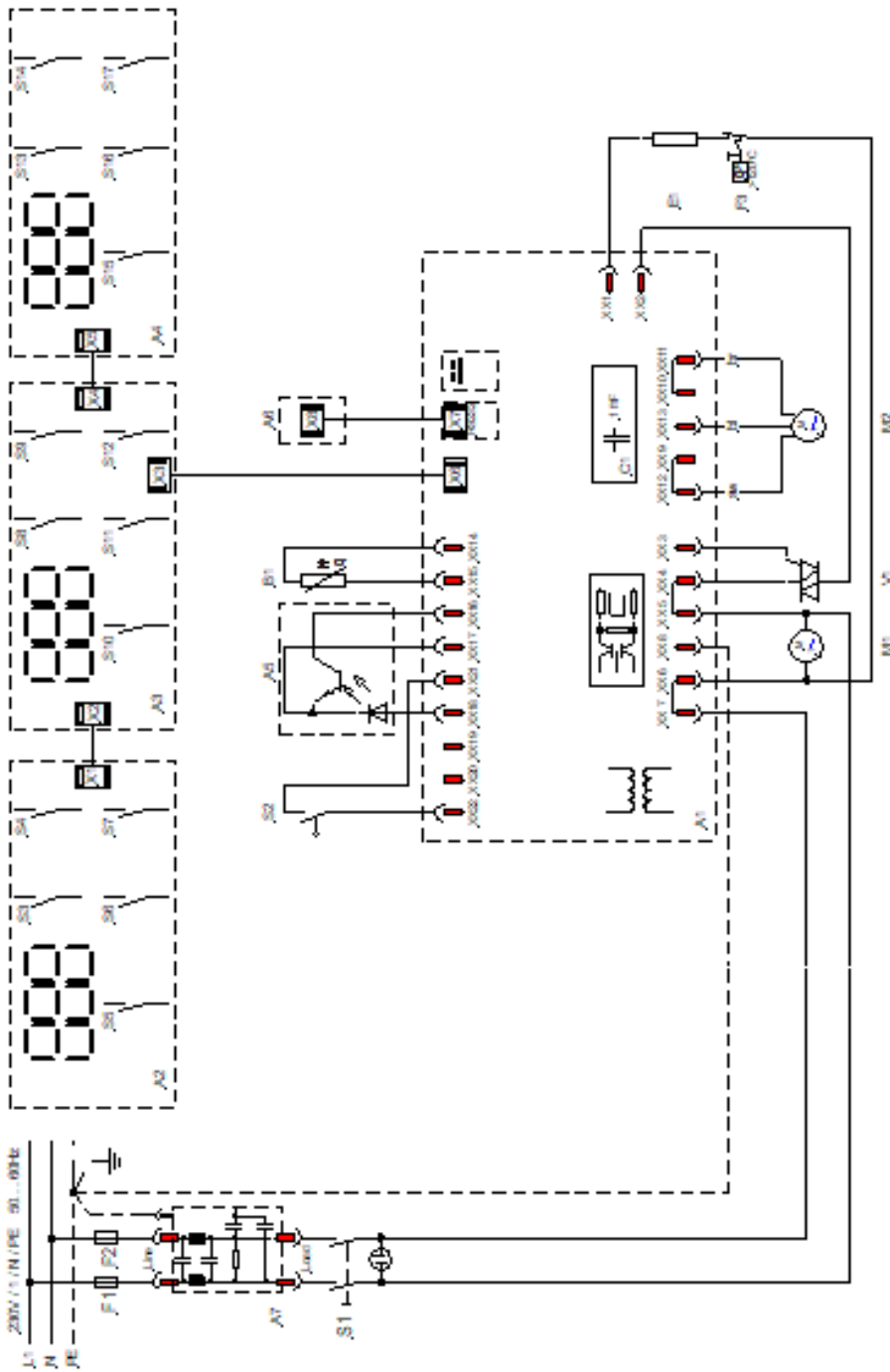

13 Connection to the mains supply

LAUDA Varioshake Shaking Incubators are supplied with a pre-assembled, cast-on shock-proof plug (CEE 7/7). Make sure to connect to a protective conductor terminal.

Colour decoding

ge/gr – yellow/green

bl – blue

sw – black

Stromnetz

PE (Protective earth)

N

L1

13.1 Electrical fuses

Type	Power	Power consumption at mains voltage *	On-site mains fuses (F4, F5)
VS 60 OI	0.65 kW	3.0 A at 230 V	10 A (max. 16 A)

* see nameplate

14 List of spare parts

14.1 Varioshake Shaking Incubator VS 60 OI

Pos. No.	Part-No.	Article
1	0012268	Heating element 230 V 500 W
2	0012430	Micro switch
3	0012843	Triac
4	A00	Gas pressure spring
5	0015533	Pivot shaft
6	0026283	Angular ball bearing
7	0015522	Ball bearing seat
8	A000097	Pulse generator
9	0014315	Stand
10	A000073	Motor
	0015531	Belt pulley for motor
11	A000112	Driving belt
12	0026285	Flat spring (complete set)
13	0013111	Temperature sensor PT 100
14	A000092	Temperature limiter
15	0030010	Mains connection cable
16	0012044	Plug
	0012045	Drawer
	0012902	Fuse 4A T
17	0013757	Microprocessor temperature regulator
18	0013759	Microprocessor shaking frequency display
19	0013768	Microprocessor power board
20	0013758	Microprocessor timer
21	A000127	Main switch
22	0014413	Hinge
23	0012166	Radial fan
	0012154	Protection shield for fan

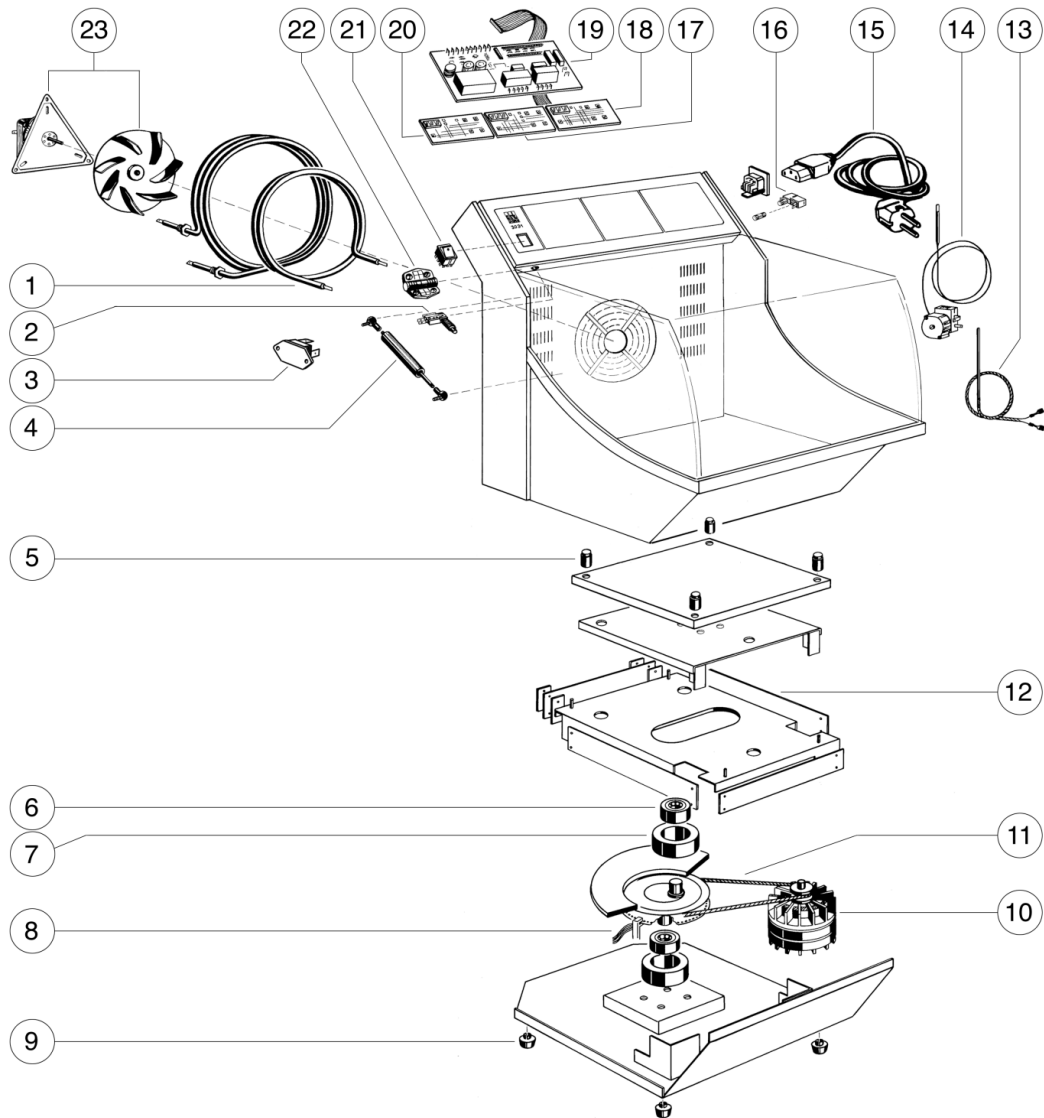

When ordering spare parts, please always state type and serial number of the unit in question.

15 Accessories

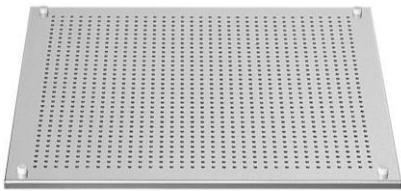

Shaking Tray with holes to fix clamps for Erlenmeyer flasks and test tube rack A000059

Part-No. A000045 made of stainless steel



Test Tube Rack, seat for test tubes can be tilted by 90 ° for easy loading, with springs for firm hold and silent shaking of the tubes. Supplied complete with fixing material, to be screwed on to a shaking tray.

Part-No. A000059 for max. 24 tubes,
12 - 17 mm Ø, length 75 - 160 mm

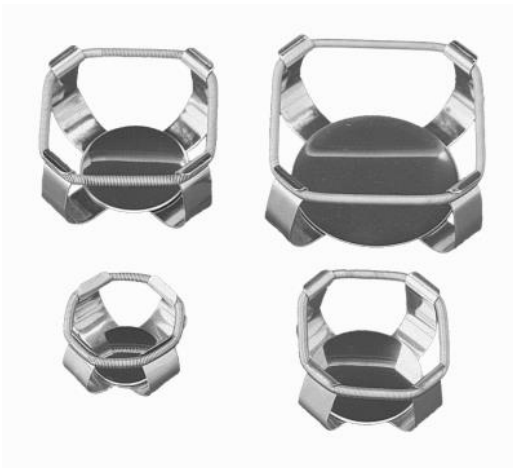

Clamps for Erlenmeyer flasks, made of stainless steel. Supplied complete with fixing material, to be screwed onto a shaking tray.

Part-No. A000025	for	25 ml Erlenmeyer flasks
Part-No. A000026	for	50 ml Erlenmeyer flasks
Part-No. A000027	for	100 ml Erlenmeyer flasks
Part-No. A000028	for	200 ml Erlenmeyer flasks
Part-No. A000029	for	250-300 ml Erlenmeyer flasks
Part-No. A000030	for	500 ml Erlenmeyer flasks
Part-No. A000031	for	1000 ml Erlenmeyer flasks
Part-No. A000053	for	2000 ml Erlenmeyer flasks



Universal mount for safe fixing of various shaking objects between rubber-coated bars.

Part-No. A000049 with 6 rubber-coated bars



Adhesive mat, black. Strong adhesive special mat for easy attachment of different vessels onto the shaking platform or tray. Max. shaking speed: up to 250 min^{-1} (depending on shape and weight of the vessel as well as on the shaking amplitude). Dimensions: 200 mm x 200 mm, the mat can be cut or trimmed with scissors. Operation temperature range: 15 to 50 °C

Part-No. A000041

Adhesive mat, black

EC DECLARATION OF CONFORMITY

Hereby we,

LAUDA-GFL Gesellschaft für Labortechnik mbH
Schulze-Delitzsch-Str. 4+5
30938 Burgwedel
Federal Republic of Germany

declare that the below stated **Varioshake Shaking incubator** models:

VS 60 OI, VS 45 OI and VS 150 OI

with the technical data:

**230 V, 50 / 60 Hz
0.8 kW**

are in conformity with the following EC Directives:

I	2006/42/EC	(Machinery Directive)
II	2014/30/EU	(EMC Directive)
III	2011/65/EU + (EU) 2015/863	(RoHS Directive)

For conformity **with I** the following standards were applied:

EN 61010 - 1:2010

For conformity **with II** the following standard was applied:

EN 61326-1:2013

Authorized representative for the compilation of the technical documentation:

Mr Florian Wunderling at LAUDA-GFL

LAUDA-GFL Ges. für Labortechnik mbH



Andreas Degmayr
Managing director

Burgwedel, 01 July 2020

LAUDA-GFL Gesellschaft für Labortechnik mbH
Schulze-Delitzsch-Str. 4/5 · 30938 Burgwedel · DE

WEEE-Reg.-Nr.: DE 67770231
Amtsgericht Hannover · HRB 120071
VAT-ID.-No. DE 115042911

Commerzbank AG Hannover
IBAN DE61 2504 0066 0141 2089 00
BIC COBA DE FF XXX

T +49 (0) 5139 9958-0 · F +49 (0) 5139 9958-21
info@lauda-gfl.de · www.lauda-gfl.de

Geschäftsführer:
Andreas Degmayr

Sparkasse Hannover
IBAN DE88 2505 0180 1050 2062 65
BIC SPKH DE 2H XXX

LAUDA-GFL Gesellschaft für Labortechnik mbH
Schulze-Delitzsch-Straße 4+5 • 30938 Burgwedel • Germany
Tel.: +49 (0) 5139 9958-0 • Fax +49 (0) 5139 9958-21
E-Mail: info@lauda-gfl.de • Internet: www.GFL.de